

Albert Lee and Hogan's Heroes

10th October 2008

Technical Specification (1 of 3 pages)

Stage Area: 6M x 5M minimum

Front of House Sound System:

A good quality 3 way system adequate for the size of venue, providing full coverage for the audience. A 5 way monitor mix into 7 wedges is required.

24 channel mixing desk (Min), preferably with 4 or more subgroups with inserts, positioned in the main auditorium.

Minimum of 4 Pre and 2 Post fade sends required. Minimum 4 effects returns required (2 x stereo).

1 x stereo 31 band graphic EQ for FOH and one 31 band EQ for each monitor send.

We carry an effects/processing rack but a standard FOH rack should be provided where possible.

1 x CD Player required.

All Microphones / Stands / DI Boxes / Cables required (we don't carry any).

Channel List and Microphone / DI Box Requirements

Channel	Item	Preference	Notes	Monitor	Processing	Subgroup
Channel 1	Kick	Beyer M88	Lay inside drum	A-D	Gate	1-2
Ch 2	Snare	SM 57		A-D	Gate	1-2
Ch 3	Hi-Hat	AKG 451		A-D		1-2
Ch 4	Rack 1	beta 56		A	Gate	1-2
Ch 5	Rack 2	beta 56		A	Gate	1-2
Ch 6	Rack 3	beta 56		A	Gate	1-2
Ch 7	Floor Tom	beta 56		A	Gate	1-2
Ch 8	O/H S/R	AKG 414				L-R
Ch 9	O/H S/L	AKG 414				L-R
Ch 10	Bass	XLR	Amp has XLR out	A-B-E	Comp	L-R
Ch 11	Guitar	Senn 609	Any speaker	A-E		L-R
Ch 12	Accordion S/R	DI Box	Mono	A-E	Comp	L-R
Ch 13	Piano Left S/R	DI Box	Left	A-E		3-4
Ch 14	Piano Right S/R	DI Box	Right	A-E		3-4
Ch 15	Piano C/S	DI Box	Left	A-C-E		L-R
Ch 16	Piano C/S	DI Box	Right	A-C-E		L-R
Ch 17	Steel Guitar	Senn 609/SM57		A-E		L-R
Ch 18	Vocal 1	SM 58	S/R Key Vox	A-E	Group Comp	5-6
Ch 19	Vocal 2	SM 58	BV (Bass)	A-B-E	Group Comp	5-6
Ch 20	Vocal 3	SM 58	Albert Vox	A-C-E	Group Comp	5-6
Ch 21	Vocal 4	SM 58	Albert Vox (key)	A-C-E	Group Comp	5-6
Ch 22	Vocal 5	SM 58	Drum Vox	A-E	Group Comp	5-6
Stereo/mono	FX Return	Rev/Delay (tap)	Vocals			L-R
Stereo	FX Return	Rev	Vocals/kit/backline			L-R

Stereo subgroup compressors used for kit and vocals
Reverb and tap delay for vocals. Reverb for drums/backline
VCA's and subgroups required for large gigs and festivals

Please note this is a minimum spec and is for guidance only.

Contact Engineer: Trev Wilkins. +44 (0)7780 937 393 (Mobile)

trev@tightdigital.co.uk

Albert Lee and Hogan's Heroes Monitors etc.

(2 of 3 pages)

Musician	Instrument	Monitor needs	Notes
Peter Baron Monitor E Subs not required as no drums in mix	Drummer/backing vocals Lead vocals	Own vocal plus all except drums, plenty of Albert's and Elio's vocal. Single wedge OK	Takes lead vocal on some songs. Needs good vocal mix for harmonies.
Elio Pace Monitor A	Keys stage right. Accordion Vocals	Own keys and vocals plus all vocals, drums, guitar and steel. Pair of wedges.	Needs a pair of monitors. Takes lead vocal on some songs.
Brian Hodgson Monitor B	Bass guitar and backing vocals	Own vocal plus some bass. Single wedge OK	BV's on some songs.
Albert Lee Monitor C is a pair of monitors	Guitar, lead vocals and keys at front position. Please note two mic positions.	Own vocal and front keys. Pair of wedges	Please mute the vocal mic that is not in use. Monitors to cover both positions from centre.
Gerry Hogan Monitor D	Steel guitar	Kick. Single wedge OK	Mainly kick. May not need others at small venues.

Important Notes

All equipment supplied should be working and fit for the purpose intended.

The specification and notes are of the minimum requirement. If in doubt please call us.

A minimum of two stage-hands will be needed to assist with the load in *and* out.

We require space to load a LWB Hi-roof van and suitable parking close by.

It would be appreciated if light refreshments are available during set-up. Thanks in advance!

Large venues and festivals please contact us if you require further details for setup.

Microphone choices are preferences only.

Please note this technical rider is as accurate as possible, if you are concerned that you cannot meet it please get in touch ASAP. We are friendly!

**If you have any questions regarding this information please contact our Engineer
Trev Wilkins:**

+44 (0)7780 937 393 (Mobile)
trev@tightdigital.co.uk

Albert Lee and Hogan's Heroes

(3 of 3 pages)

Please note we do not carry any microphones / stands / cables of our own

Microphones / Di Boxes

Microphones listed are the preferred choice, however, we understand that these may not be available and we are happy for you to provide suitable alternatives.

All DI boxes should be active.

Monitor Mix

5 way mix is required into 6 wedges preferably controlled from the stage complete with an engineer to operate. However, if this is not possible our engineer will operate from the Front of House. If only a 4-way mix is available we need to send kick drum to a separate amp/speaker with level control (such as a combo) for steel player.

Stage Layout

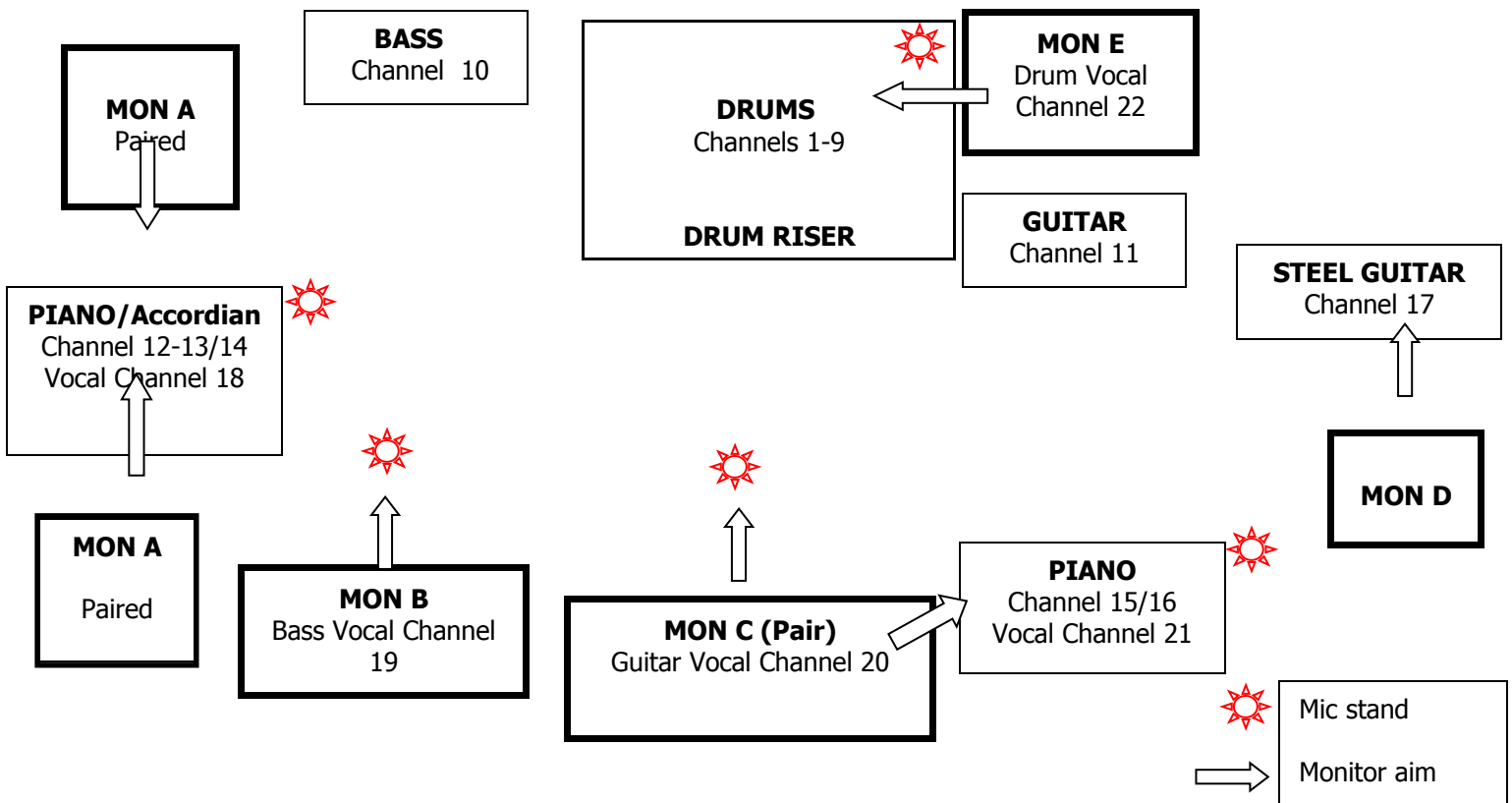

If you have any questions regarding this information please contact our Engineer Trev Wilkins:

+44 (0)7780 937 393 (Mobile)

trev@tightdigital.co.uk